

PN Series Dimension

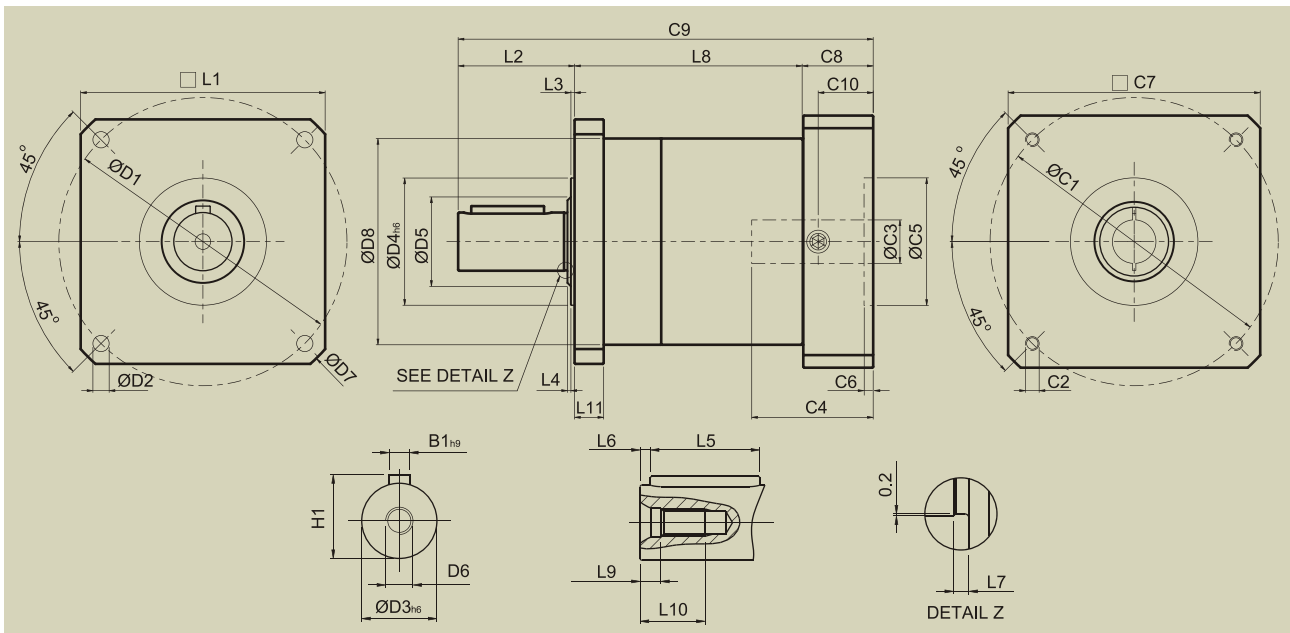

[unit: mm(inch)]

Dimension	PN023	PN034	PN042	PN056	PN075
D1	66.675(2.625)	98.425(3.875)	125.73(4.950)	177.8(7.0)	215.011(8.465)
D2	5.2(0.205)	5.6(0.220)	7.1(0.280)	10.4(0.409)	14.2(0.559)
D3 _{h6}	12.7(0.5)	19.05(0.750)	25.4(1.0)	38.1(1.5)	50.8(2.0)
D4 _{h6}	38.1(1.5)	73.025(2.875)	55.5(2.185)	114.3(4.5)	152.4(6.0)
D5	17	25	40	50	65
D6	M4X0.7P	M5X0.8P	M8X1.25P	M12X1.75P	M16X2P
D7	75	107.5	142	198	260
D8	50	70	90	120	155
L1	57.15(2.250)	82.55(3.250)	106.68(4.2)	146.05(5.750)	190(7.480)
L2	31.75	38.1	50.8	63.5	88.9
L3	1.6(0.063)	1.6(0.063)	1.6(0.063)	3.2(0.126)	4.75(0.187)
L4	1	1.5	1.5	2	2
L5	19.05(0.750)	25.4(1.0)	31.75(1.250)	38.1(1.5)	63.5(2.5)
L6	3.788(0.149)	3.8(0.150)	5.715(0.225)	8.563(0.337)	8.563(0.337)
L7	1	1	1.5	2	2
L8	1-stage	58.9	82	99.3	133.7
	2-stage	83.4	115	138.8	186.7
L9	4.5	4.8	7.2	10	12
L10	10	12.5	19	28	36
L11	6.4	7.9	12.7	19.05	22.2
C1 ⁴	66.675(2.625)	98.425(3.875)	125.73(4.950)	149.225(5.875)	165
C2 ⁴	M4X0.7P	M5X0.8P	M6X1P	11 Thru	M10X1.5P
C3 ⁴	≤ 12	≤ 16	≤ 24	≤ 32	≤ 38
C4 ⁴	32(1.260)	40(1.575)	51(2.008)	55(2.165)	60
C5 ⁴	38.15(1.502)	73.08(2.877)	55.65(2.191)	114.3(4.5)	130
C6 ⁴	3.5(0.138)	4(0.157)	4(0.157)	4(0.157)	6
C7 ⁴	55(2.165)	85(3.346)	110(4.331)	130(5.118)	157
C8 ⁴	23.5(0.925)	27.5(1.083)	31(1.220)	29(1.142)	31
C9 ⁴	1-stage	114.15(4.494)	147.6(5.811)	181.1(7.130)	226.2(8.905)
	2-stage	138.65(5.459)	180.6(7.110)	220.6(8.685)	279.2(10.992)
C10 ⁴	16.5(0.650)	21.5(0.846)	24(0.945)	21(0.827)	21
B1 _{h9}	3.175(0.125)	4.763(0.188)	6.35(0.250)	9.525(0.375)	9.525(0.375)
H1	14.125(0.556)	21.163(0.833)	28.2(1.110)	42.275(1.664)	55.125(2.170)

4. C1-C10 are NEMA motor specific dimensions (except for PN075). Refer to Apexdyna.com and Design Tool to view your specific motor mounting system.