

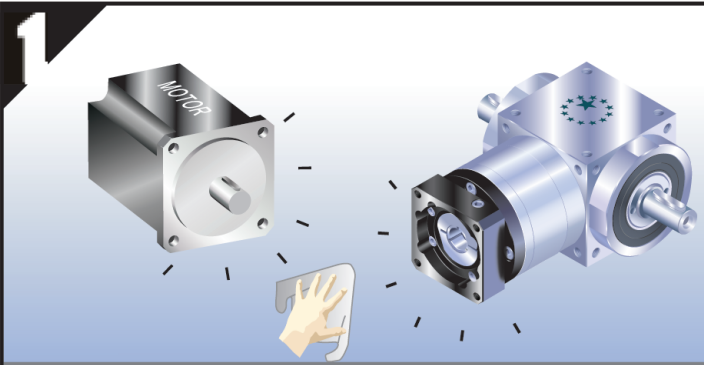

MOTOR MOUNTING INSTRUCTIONS

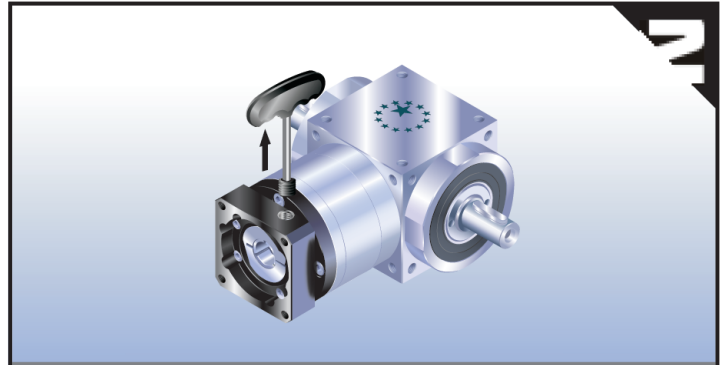

Double-check the motor and gearbox size.
Clean the mounting surface.



Remove the plug on the adapter plate.
Rotate the set collar till the bolt is line up.

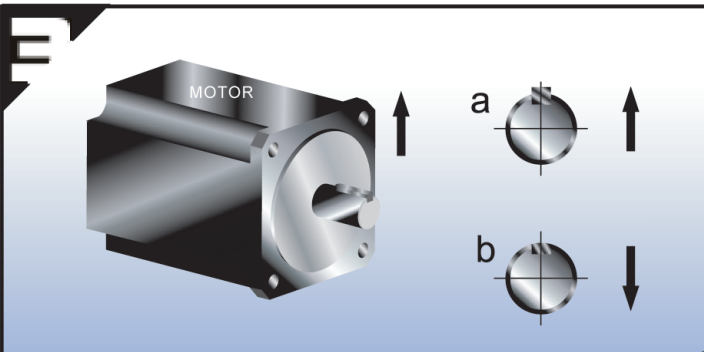

a. Remove motor key.
b. Insert balance key.

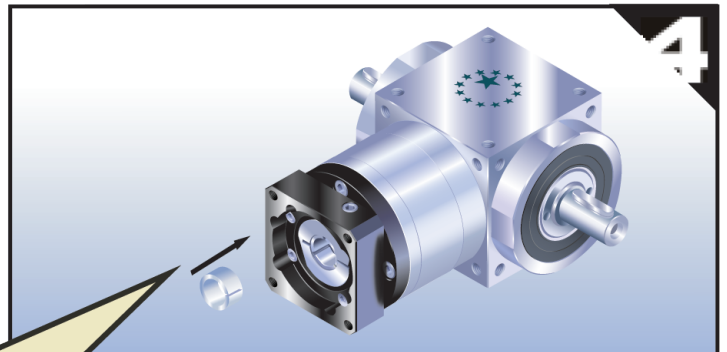

Check motor shaft size and
insert bushing if necessary.

Correct installation.
When installing on flatted shafts,
be sure to align the collet gap over
the flat and the set collar bolt
perpendicular
to the flat.

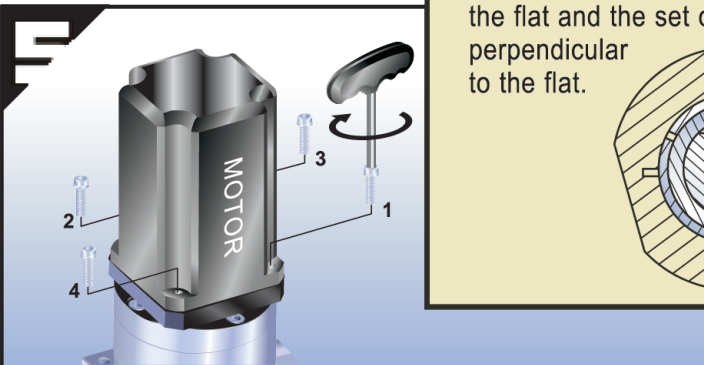

Set at vertical position. Tighten the mounting bolts
(including washer) in 1~4 order with wrench to 5%
specified torque. (See Table 1)

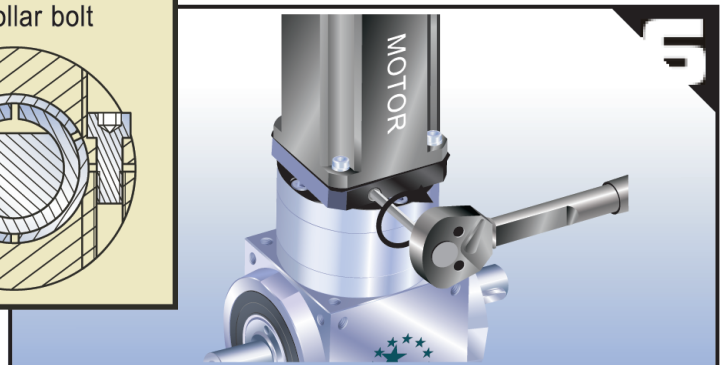

Tighten the set collar bolt with torque
wrench to specified torque. (See Table 2)

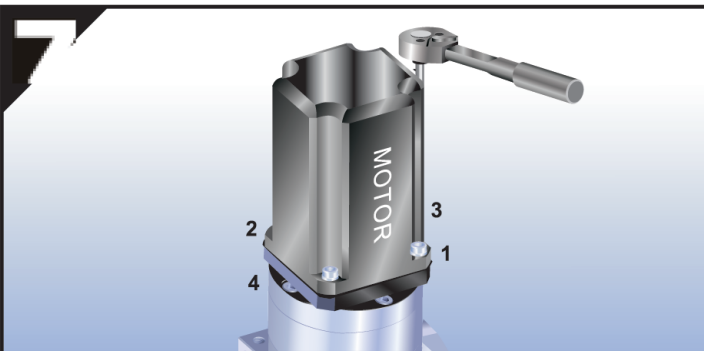

Tighten the mounting bolts in 1~4 order with
torque wrench to specified torque. (See Table 1)

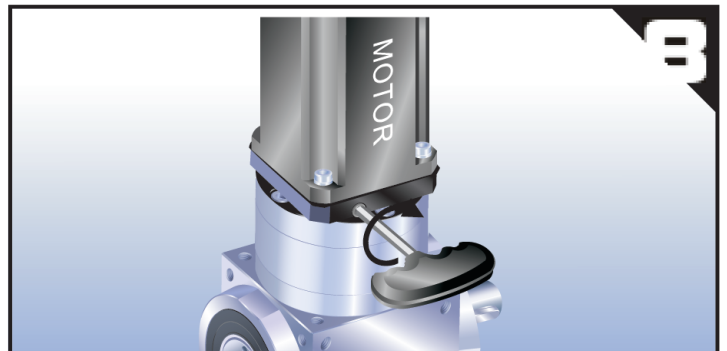

Tighten back the screw plug.

Table 1 Tightening Torque Recommended for Motor Mounting Bolt

Bolt Size	Width Across Flats	Strength 8.8 Tightening Torque		Strength 10.9 Tightening Torque		Strength 12.9 Tightening Torque	
	[mm]	[Nm]	[In-lbs]	[Nm]	[In-lbs]	[Nm]	[In-lbs]
M3 x 0.5P	2.5	1.3	12	1.8	16	2.1	19
M4 x 0.7P	3	3	27	4.1	37	4.9	44
M5 x 0.8P	4	6.1	55	8.2	73	9.8	87
M6 x 1P	5	11	98	14	124	17	151
M8 x 1.25P	6	25	222	34	302	41	364
M10 x 1.5P	8	49	434	67	594	80	709
M12 x 1.75P	10	85	753	116	1028	139	1232
M14 x 2P	12	137	1214	186	1648	223	1976
M16 x 2P	14	210	1860	286	2534	343	3038

Table 2 Tightening Torque Recommended for Set Collar Bolt

Gearbox Size		Motor Shaft Dia.	Bolt Size	Width Across Flats	Tightening Torque	
		[mm]	[mm]	[mm]	[Nm]	[In-lbs]
AT065FL / AT065FL1 AT065FH / AT065FC	1 stage	≤11	M3 x 0.5P x 8L	2.5	2.1	19
AT075FL / AT075FL1 AT075FH / AT075FC	1 stage	≤14	M4 x 0.7P x 12L	3	4.9	44
AT090FL / AT090FL1 AT090FH / AT090FC	1 stage	≤19	M5 x 0.8P x 14L	4	9.8	87
AT110FL / AT110FL1 AT110FH / AT110FC	1 stage	≤24	M5 x 0.8P x 14L	4	9.8	87
AT140FL / AT140FL1 AT140FH / AT140FC	1 stage	≤32	M6 x 1P x 16L	5	17	151
AT170FL / AT170FL1 AT170FH / AT170FC	1 stage	≤38	M8 x 1.25P x 20L	6	41	364
AT210FL / AT210FL1 AT210FH / AT210FC	1 stage	≤42	M8 x 1.25P x 20L	6	41	364
AT240FL / AT240FL1 AT240FH / AT240FC	1 stage	≤48	M10 x 1.5P x 25L	8	80	709
AT280FL / AT280FL1 AT280FH / AT280FC	1 stage	≤55	M12 x 1.75P x 30L	10	139	1232

Note: Holding torques must be bigger than values shown above. Bolts can be tightened up to 20% higher for increased holding torques.



APEX DYNAMICS, INC.

Tel : 886-4-23550219 / Fax : 886-4-23550218

E-Mail : sales@apexdyna.com / Web : www.apexdyna.com

NO.10.Keyuan.3rd.Rd.Situn District.Taichung City.407.Taiwan(R.O.C)



MOTOR MOUNTING INSTRUCTIONS

1

Double-check the motor and gearbox size. Clean the mounting surface.

2

a. Remove the motor key.
b. Insert balance key.

3

Check motor shaft size and insert bushing.

Correct installation.

When installing the bushing, be sure to align the collet gap perpendicular to set screw.

4

Set at vertical position. Tighten the mounting bolts (including washer) in 1~4 order with wrench to 5% specified torque. (See Table 1).

5

Tighten the set screw with torque wrench to specified torque (See Table 2)

6

Tighten the mounting bolts in 1~4 order with torque wrench to specified torque. (See Table 1).

7

Insert the plug.

Table 1 Tightening Torque Recommended for Motor Mounting Bolt

Bolt Size	Width Across Flats	Strength 8.8 Tightening Torque		Strength 10.9 Tightening Torque		Strength 12.9 Tightening Torque	
	[mm]	[Nm]	[In-lbs]	[Nm]	[In-lbs]	[Nm]	[In-lbs]
M3 x 0.5P	2.5	1.3	12	1.8	16	2.1	19
M4 x 0.7P	3	3	27	4.1	37	4.9	44
M5 x 0.8P	4	6.1	55	8.2	73	9.8	87
M6 x 1P	5	11	98	14	124	17	151
M8 x 1.25P	6	25	222	34	302	41	364
M10 x 1.5P	8	49	434	67	594	80	709
M12 x 1.75P	10	85	753	116	1028	139	1232
M14 x 2P	12	137	1214	186	1648	223	1976
M16 x 2P	14	210	1860	286	2534	343	3038

Table 2 Tightening Torque Recommended for Set Collar Bolt

Gearbox Size		Motor Shaft Dia.	Bolt Size	Width Across Flats	Tightening Torque	
		[mm]	[mm]	[mm]	[Nm]	[In-lbs]
AT065FL / AT065FL1 AT065FH / AT065FC	2 stage	≤12	M6 x 1P x 8L	3	5.6	50
AT075FL / AT075FL1 AT075FH / AT075FC	2 stage	≤12	M6 x 1P x 8L	3	5.6	50
AT090FL / AT090FL1 AT090FH / AT090FC	2 stage	≤16	M8 x 1.25P x 10L	4	9.5	85
AT110FL / AT110FL1 AT110FH / AT110FC	2 stage	≤24	M10 x 1.5P x 12L	5	23	205
	3 stage	≤12	M6 x 1P x 8L	3	5.6	50
AT140FL / AT140FL1 AT140FH / AT140FC	2 stage	≤24	M10 x 1.5P x 12L	5	23	205
	3 stage	≤12	M6 x 1P x 8L	3	5.6	50
AT170FL / AT170FL1 AT170FH / AT170FC	2 stage	≤24	M10 x 1.5P x 12L	5	23	205
	3 stage	≤16	M8 x 1.25P x 10L	4	9.5	85
AT210FL / AT210FL1 AT210FH / AT210FC	2 stage	≤32	M12 x 1.75P x 16L	6	45	400
	3 stage	≤16	M8 x 1.25P x 10L	4	9.5	85
AT240FL / AT240FL1 AT240FH / AT240FC	2 stage	≤38	M16 x 2P x 20L	8	78	693
	3 stage	≤24	M10 x 1.5P x 12L	5	23	205
AT280FL / AT280FL1 AT280FH / AT280FC	2 stage	≤38	M16 x 2P x 20L	8	78	693
	3 stage	≤24	M10 x 1.5P x 12L	5	23	205

Note: Holding torques must be bigger than values shown above. Bolts can be tightened up to 20% higher for increased holding torques.



APEX DYNAMICS, INC.

Tel : 886-4-23550219 / Fax : 886-4-23550218

E-Mail : sales@apexdyna.com / Web : www.apexdyna.com

NO.10.Keyuan.3rd.Rd.Situn District.Taichung City.407.Taiwan(R.O.C)