

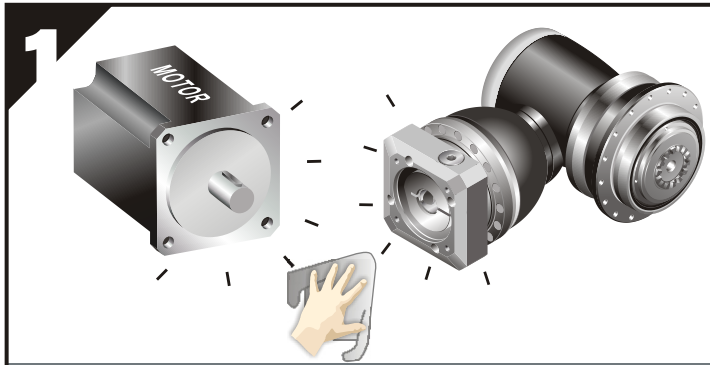

MOUNTING INSTRUCTION (APK Series)

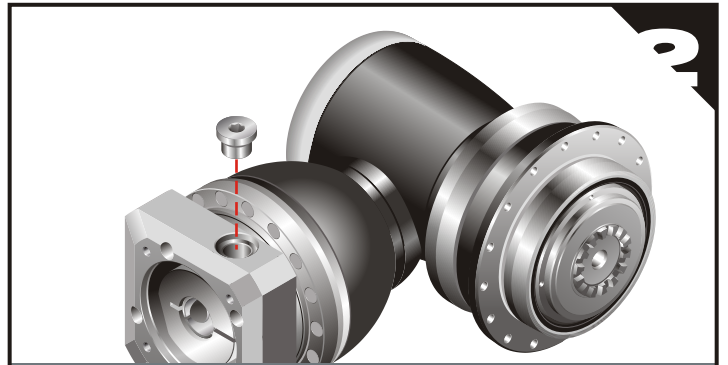

Double-check the motor and gearbox size and spec, Clean the both mounting surface.



Remove the plug on the adapter and rotate the set collar till the bolts line up with plug hole.

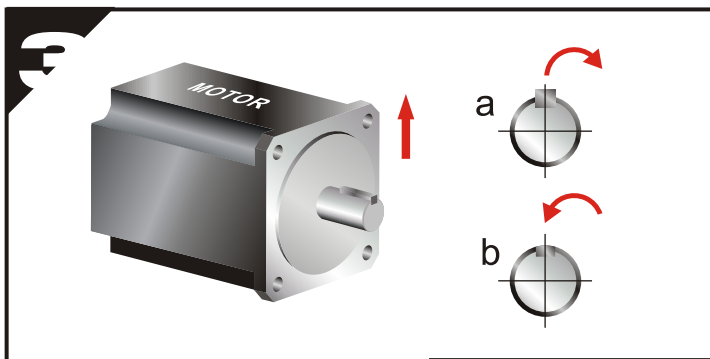

a. Remove motor key
b. Insert balance key if necessary

Correct installation.
When installing on flatted shafts, be sure to align the collet gap over the flat and the set collar bolt perpendicular to the flat.

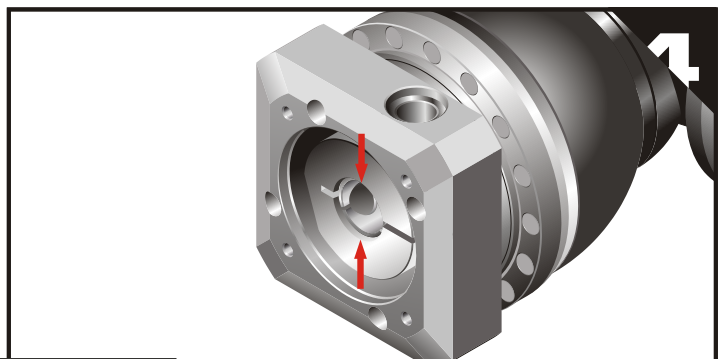

Check motor shaft size and insert bushing if necessary.

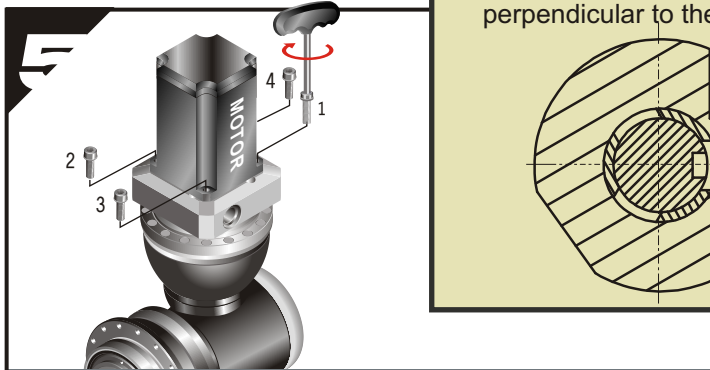

Set at vertical position. Tighten the mounting bolts (including washer) on following order(1 to 4) with wrench to 5% specified torque.(Please refer to Table 1)

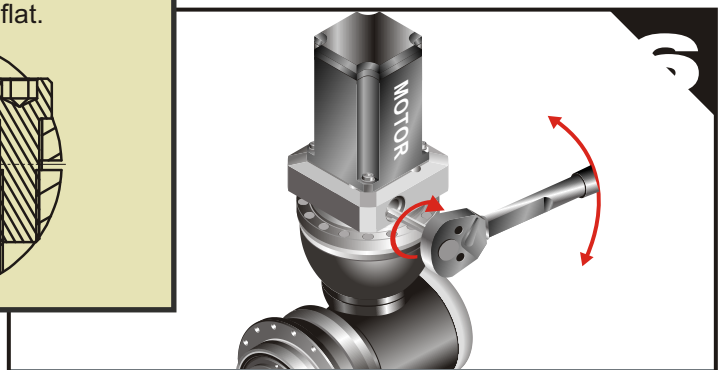

Tighten the set collar bolt with torque wrench to specified torque.(Please refer to table 2)

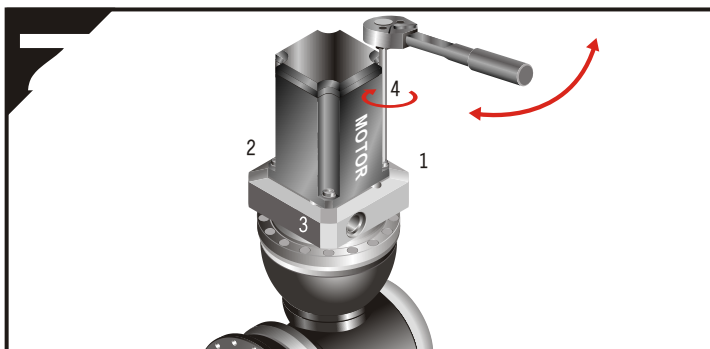

Tighten the mounting bolts with following order(1 to 4) by torque wrench to specific torque. (Please refer to Table 1)

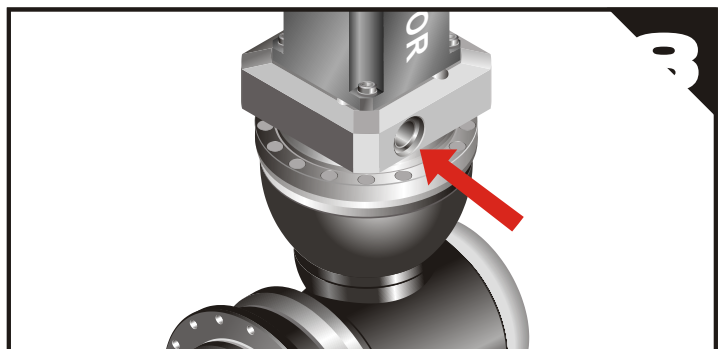

Tighten back the screw plug.

Accessories Mounting Instructions

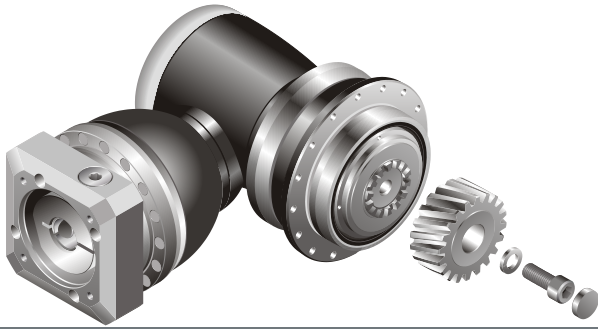

Assemble with chosen gears and refer to table 2 for specific torque on fixing screw with torque wrench. Curvic design allows users to adjust optimized run-out by rotated angles.

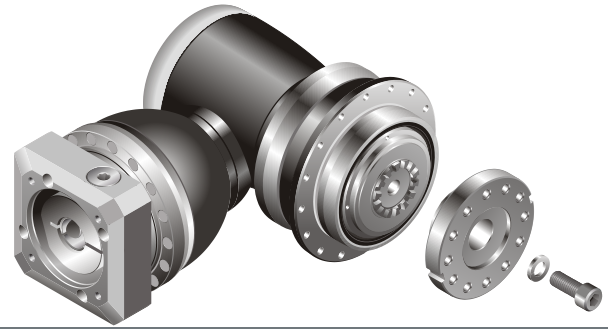

Assemble with chosen curvic flange and refer to table 2 for specific torque on fixing screw with torque wrench. Curvic design allows users to adjust optimized run-out by rotated angles.

Table 1 Tightening Torque Recommended for Motor Mounting Bolt

Bolt Size	Width Across Flats [mm]	Strength 8.8 Tightening Torque		Strength 10.9 Tightening Torque		Strength 12.9 Tightening Torque	
		[Nm]	[In-lbs]	[Nm]	[In-lbs]	[Nm]	[In-lbs]
M3 x 0.5P	2.5	1.3	12	1.8	16	2.1	19
M4 x 0.7P	3	3	27	4.1	37	4.9	44
M5 x 0.8P	4	6.1	55	8.2	73	9.8	87
M6 x 1P	5	11	98	14	124	17	151
M8 x 1.25P	6	25	222	34	302	41	364
M10 x 1.5P	8	49	434	67	594	80	709
M12 x 1.75P	10	85	753	116	1,028	139	1,232
M14 x 2P	12	137	1214	186	1,648	223	1,976
M16 x 2P	14	210	1860	286	2,534	343	3,038

Table 2 Tightening Torque Recommended for Set Collar Bolt and Curvic Pinion/Flange

Model	Curvic Pinion / Flange	ϕ (C3)		8	11	14	19	24	28	32	35	38	42	48	55	60
		Stage	Ratio													
APK 110	M12	2-st	22~55	-	-	-	M8	M10	-	-	-	-	-	-	-	-
		3-st	88~385	-	-	M6	M6	M10	-	-	-	-	-	-	-	-
		4-st	440~5,500	M5	M5	-	-	-	-	-	-	-	-	-	-	-
APK 140	M16	2-st	22~55	-	-	-	-	M10	M10	M10	M12	M12	-	-	-	-
		3-st	88~385	-	-	-	M8	M10	M10	-	-	-	-	-	-	-
		4-st	440~5,500	-	-	M6	M6	M10	-	-	-	-	-	-	-	-
APK200	M20	2-st	22~55	-	-	-	-	-	-	M10	M12	M12	M12	M16	-	-
		3-st	88~385	-	-	-	-	M10	M10	M10	M12	M12	-	-	-	-
		4-st	440~5,500	-	-	-	M8	M10	-	-	-	-	-	-	-	-
APK255	M24	2-st	22~55	-	-	-	-	-	-	-	M12	M12	M12	M16	-	-
		3-st	88~385	-	-	-	-	-	M10	M10	M12	M12	-	-	-	-
		4-st	440~5,500	-	-	-	-	M10	M10	M10	M12	M12	-	-	-	-
APK285	M30	2-st	22~55	-	-	-	-	-	-	-	-	M12	M12	M16	-	-
		3-st	88~385	-	-	-	-	-	-	-	M12	M12	M12	M16	-	-
		4-st	440~5,500	-	-	-	-	-	-	-	M12	M12	M12	M16	-	-
APK 355	M30	2-st	22~55	-	-	-	-	-	-	-	-	-	M12	M16	M16	-
		3-st	88~385	-	-	-	-	-	-	-	-	M12	M12	M16	-	-
		4-st	440~5,500	-	-	-	-	-	-	-	M12	M12	M12	M16	-	-
APK450	M36	3-st	88~385	-	-	-	-	-	-	-	M12	M12	M12	M16	-	-
		4-st	440~5,500	-	-	-	-	-	-	-	M12	M12	M12	M16	-	-
APK 110	M12	2-st	5.5~11	-	-	-	M8	M10	M10	M10	M12	M12	-	-	-	-
APK 140	M16	2-st	5.5~11	-	-	-	-	M10	M10	M10	M12	M12	M12	M16	-	-
APK200	M20	2-st	5.5~11	-	-	-	-	-	-	-	M12	M12	M12	M16	-	-
APK255	M24	2-st	5.5~11	-	-	-	-	-	-	-	-	-	M12	M16	M16	-
APK285	M30	2-st	5.5~11	-	-	-	-	-	-	-	-	-	-	M16	M16	M16

Bole Size	[mm]	M5 x 0.8P	M6 x 1P	M8 x 1.25P	M10 x 1.5P	M12 x 1.75P	M16 x 2P	M20 x 2.5P	M24 x 3P	M30 x 3.5P	M36 x 4P
Width Across Flats	[mm]	4	5	6	8	10	14	17	19	22	27
Tightening Torque	[Nm]	9.8	17	41	80	139	343	660	1,140	2,300	4,100
	[In-lbs]	87	151	364	709	1,232	3,038	5,846	10,098	20,372	36,316

NOTE: Tightening Torque values can be exceeded by 20% for increased clamping force.



APEX DYNAMICS, INC.

No10, Keyuan 3rd RD, Situng District, Taichung City 40763, Taiwan (R.O.C)
Tel: 886-4-24650219 | Fax: 886-4-24650118
sales@apexdyna.com | http://www.apexdyna.com



APEX-2017-04-1C